

Vse dimenzije so v milimetrih./All dimensions are in millimetres.

Bat Piston Ø	MM Ø	A	B Ø	CH	X	D Ø	EE	KK	NA Ø	WF	VE	Y	PJ
25	14	17	35	12	32	20	G 1/4	M 12×1.25	13	17	8	43	18*
32	20	19	42	15	36	20	G 1/4	M 14×1.5	17	20	10	61	38*
40	22/ 28	16	50	17	41	26	G 3/8	M 16×1.5	20	25	10	69	42
50	28/ 36	16	60	22	46	26	G 3/8	M 16×1.5	25	25	10	75	45
63	36/ 45	23	75	30	56	30	G 1/2	M 22×1.5	34	26	10	87	48
70	40/ 45	23	85	30	60	30	G 1/2	M 22×1.5	34	26	10	83	56
80	45/ 56	35	95	36	66	30	G 1/2	M 35×1.5	40	27	10	97	53
90	40/ 50	35	105	36	70	30	G 1/2	M 35×1.5	38	27	10	93	66
100	56/ 63/ 70	45	115	46	78	38	G 3/4	M 45×1.5	50	27	10	112	62
110	63/ 70	45	130	46	86	38	G 3/4	M 45×1.5	50	27	10	107	72
125	70/ 90	58	145	60	93	38	G 3/4	M 58×1.5	65	32	12	128	63
140	80/100	65	165	65	104	45	G 1	M 65×1.5	75	32	12	142	75
160	90/110	80	190	80	119	45	G 1	M 80×2	85	40	15	155	75
180	110/125	80	220	80	134	45	G 1	M 80×2	90	50	20	170	75
200	125/140	110	245	110	144	45	G 1	M 110×2	120	50	20	190	75
250	140/160	125	300	120	175	45	G 1	M 120×3	130	58	20	198	107

* Pri hodu do 10 mm se PJ in ZP podaljšata za 10 mm./At stroke up to 10 mm PJ and ZP are extend for 10 mm.

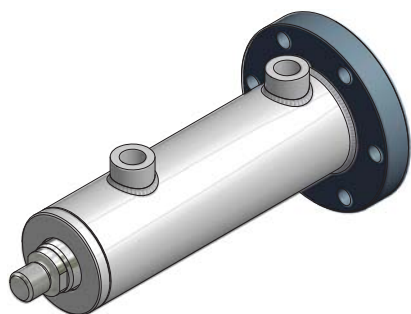

Bat Piston Ø	ZP	VD	NF	BC Ø e8	FC	UC	FB
25	98*	3	8	45	65	85	9
32	129*	3	10	55	75	95	9
40	142	3	14	65	85	104	11
50	158	3	17	75	95	118	11
63	177	3	22	90	115	138	13
70	180	3	25	100	125	158	13
80	208	3	27	115	145	178	17
90	208	3	27	125	155	188	17
100	231	3	32	140	170	205	17
110	231	3	32	160	190	225	17
125	255	3	35	165	205	245	21
140	285	3	35	200	250	300	26
160	310	3	40	225	275	335	30
180	335	3	50	255	310	380	30
200	360	3	50	285	345	410	33
250	405	3	60	345	405	470	33